



thirstywork

we're all about water!

LK-MaxUV

Mains Fed • Wall Mounted • Ambient • Filtered



Optional
bespoke
branding

Can be
fixed to the
wall or floor

trial it, love it, keep it!

Request your no obligation 10 day trial

Call **01392 877172** Email **hello@thirstywork.com**

www.thirstywork.com/free-trial

LK-MaxUV

Mains fed, surface-mounted, bottle filler



KEY FEATURES

- Electronic sensor activated bottle filler
- Mounted to wall or floor for indoor use
- Optional remote chiller for refrigeration
- Ultraviolet water sterilisation system
- Laminar flow provides minimal splash
- Silver Ion Antimicrobial protection on key plastic components to inhibit the growth of mould and mildew
- Full filter change and servicing package included
- Built-in drainage eliminates standing water
- Optional branded vinyl wrap
- With **pura** filtration
- Optional **puraguard** Antibacterial and antiviral protection

The LK-MaxUV high-performance water dispenser has been designed for durability - with rust-proof, vandal-proof and incredibly strong properties. It is wheelchair accessible and can be secured to either the wall or floor using pre-drilled location holes. The external cabinet is small and unobtrusive, taking up minimal floor space.

This machine is easy to install and the wipe-clean exterior means that everyday maintenance is kept to a minimum. Delivering an unlimited supply of filtered water, this bottle filler would make the perfect addition to any eco-conscious business, school, transport hub, shopping centre or factory.

The integrated Green Ticker informs users just how many 20oz plastic water bottles have been saved from waste through the use of the refill station.

COLOUR OPTIONS



Stainless Steel



Bespoke Vinyl Wrap

WATER OPTIONS



Ambient



Chilled option



Filtered

INSTALLATION OPTIONS



Wall mounted



Floor-standing

DIMENSIONS

Height:	1690mm
Width:	610mm
Depth:	309mm

DIMENSIONS LK-MaxUV Surface-mounted, bottle filler

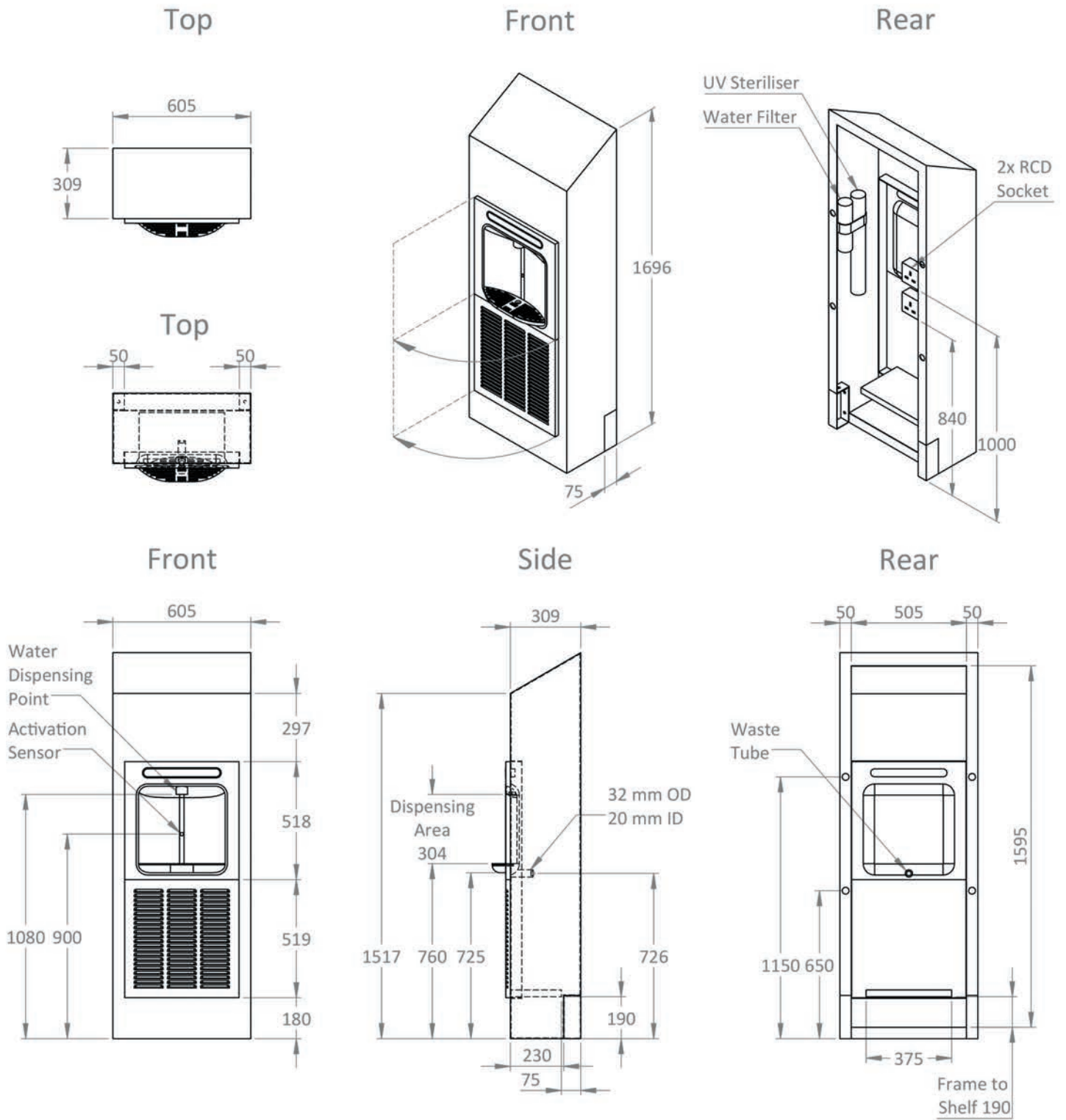

Information correct at time of printing, please check manufacturer website for latest installation information.

INSTALLATION INFORMATION LK-MaxUV surface-mounted, bottle filler

Installation with services enclosed in cabinet

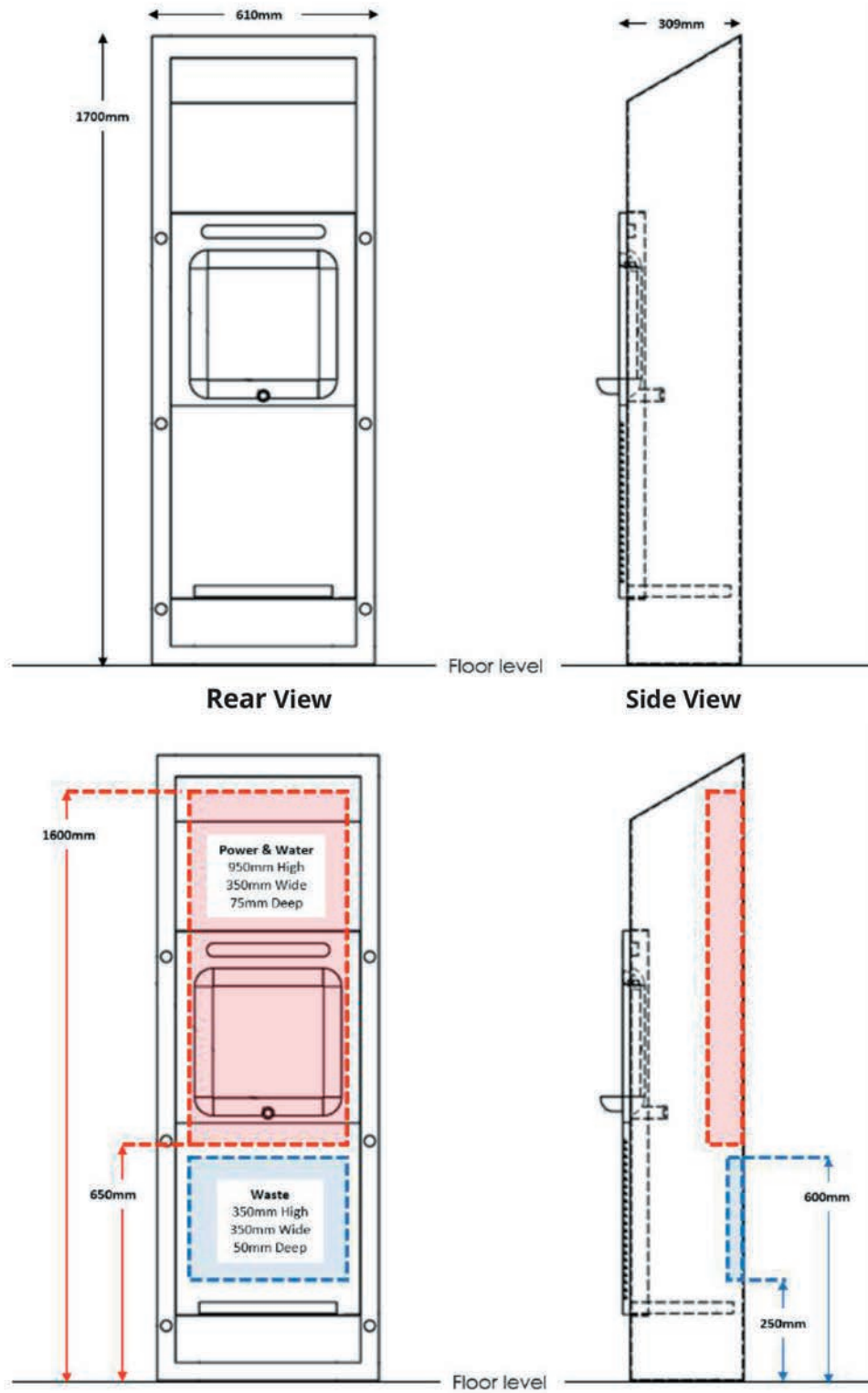

Important Note: *The waste pipe must not exceed 50mm from the wall where a chiller is fitted*

Information correct at time of printing, please check manufacturer website for latest installation information.

INSTALLATION INFORMATION LK-MaxUV surface-mounted, bottle filler

Installation with services entering from rear

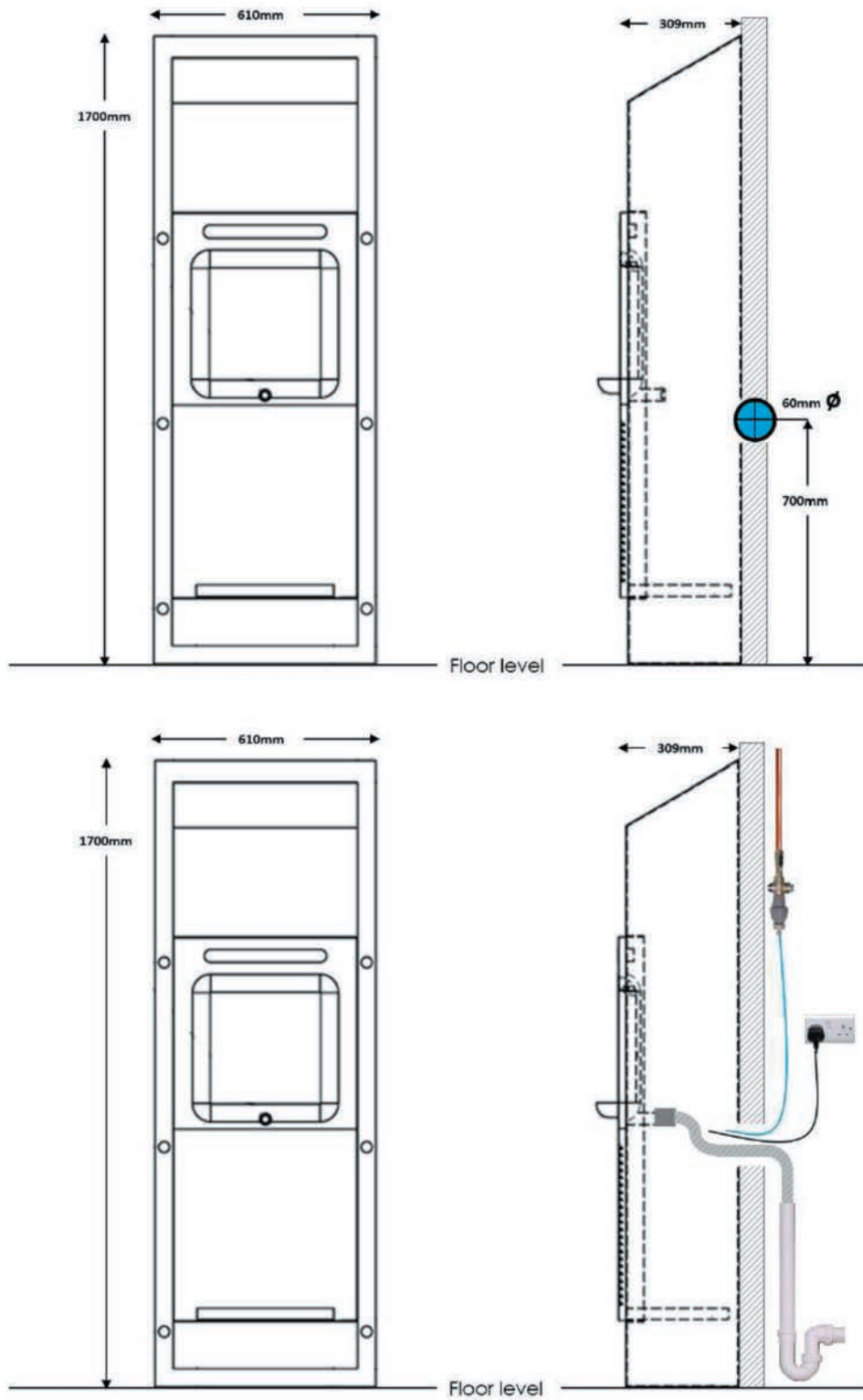

Important Note: All services should be within 1 metre of 60mm \varnothing hole in wall

Information correct at time of printing, please check manufacturer website for latest installation information.

FULL SPECIFICATION LK-MaxUV Wall-mounted, bottle filler

Rated input	216W
Throughput litres per hour	80L/h
Dimensions	610mm (W) x 309mm (D) x 1690mm (H)
	Dispense height: 310mm

AVAILABLE ACCESSORIES



Paper Cups

- 7oz recyclable paper cups
- 7oz biodegradable and compostable paper cups
- 4oz paper cones



Branded Wrap

From train stations to shopping centres, health facilities and schools, you have the ability to create an impact and add your own message to the external cabinet



Remote Chiller

- Non-filtered
- Can be placed anywhere within 10 metres of the install location
- Requires mains water and power connection
- 80 litre per hour



UV Water Steriliser

Utilising the most advanced UV technology, the unit has been designed to eliminate 99.99% of all waterborne microorganisms, including mould, bacteria and virus'

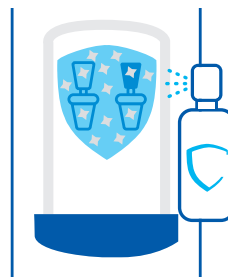

Puraguard

Puraguard is a ground-breaking protective antimicrobial coating that can be applied to your dispensers taps on request, providing 24hr protection against the growth of microbes (bacteria, moulds, fungi and virus')

trial it, love it, keep it!

Request your no obligation 10 day trial

Call **01392 877172** Email **hello@thirstywork.com**

www.thirstywork.com/free-trial