



**thirstywork**

*we're all about water!*

# VersaFiller Bottle Filler and Fountain

Chilled • Filtered



**TOUCH  
FREE  
DISPENSE**

**UV  
BACTERIA  
AND VIRUS  
CONTROL**

Call **01392 877172** Email **hello@thirstywork.com**  
**www.thirstywork.com**

# Wall Mounted Bottle Filler and Fountain

The ideal solution for busy venues



## COLOUR OPTIONS



Brushed  
Stainless  
Steel

## WATER OPTIONS



Chilled



Filtered

## INSTALLATION OPTIONS



Wall Mounted

## KEY FEATURES

- Chilled water
- Sports bottle filler and drinking fountain combination
- Electronic - touch-free bottle filler activation, and manual drinking fountain
- 30 second shut-off timer
- UVC-LED disinfection treatment at the point of dispense
- Large alcove to fit most sports bottles
- Surface wall-mounted model
- Highly efficient cooling tank
- Cooled temperature 10°C
- Designed to eliminate splashing and standing water - the water-saving bubbler reduces waste water by 50%
- Built-in drainage - no drip tray to empty
- With **pura3000** filtration
- Optional **puraguard** Antibacterial and antiviral protection

The VersaFiller hydration station is a combined chilled drinking water fountain and water bottle filler. It is ideal for busy venues, with electronic, touch-free activation and UVC-LED treatment at the point of dispense - disinfecting the water while it's being dispensed and killing 99.99% of bacteria.

Suitable for public buildings, gyms and sports complexes, hospitals, schools, and offices.

Puraguard is a ground-breaking protective antimicrobial coating that can be applied to your dispensers taps on request, providing 24hr protection against the growth of microbes (bacteria, moulds, fungi and viruses).

## DIMENSIONS

Height:	690mm
Width:	448mm
Depth:	473mm

## INSTALLATION

All dimensions are in millimetres.

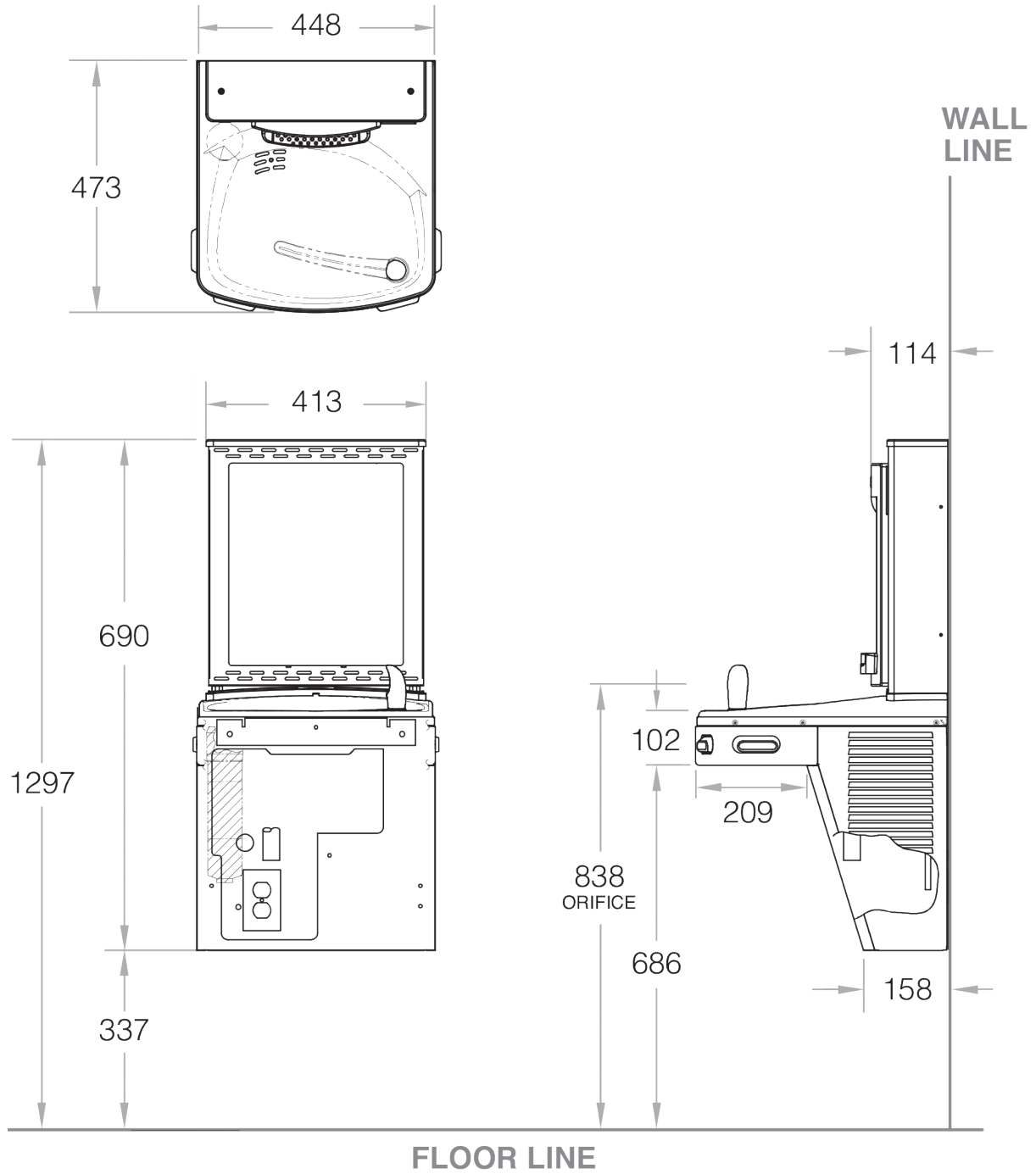

Call **01392 877172** Email **hello@thirstywork.com**  
**www.thirstywork.com**

**FULL SPECIFICATION** VersaFiller surface-mounted combined cold water fountain and bottle filler.

Power consumption	457W
Cold tank capacity	60 litres
Dimensions	448mm (W) x 473mm (D) x 690mm (H)
Weight	31kg

#### AVAILABLE ACCESSORIES



#### Paper Cups

- 7oz recyclable paper cups
- 7oz biodegradable and compostable paper cups
- 4oz biodegradable paper cones



#### Puraguard

- Antibacterial and Antiviral Protection Coating