



thirstywork

we're all about water!

VersaFountain

Chilled • Ambient • Filtered



**BACTERIA
AND VIRUS
SHIELD**

Call **01392 877172** Email **hello@thirstywork.com**
www.thirstywork.com

Wall Mounted Fountain

The ideal solution for busy venues



KEY FEATURES

- Refrigerated and non-refrigerated options
- Manually activated drinking fountain
- Antimicrobial copper push pad activation
- Delivers 60 litres per hour of chilled water below 10°C and ambient at 21°C
- Suitable for both adults and children
- Surface wall-mounted model
- Highly efficient cooling tank (refrigerated)
- Designed to eliminate splashing and standing water - the water-saving bubbler reduces waste water by 50%
- Built-in drainage - no drip tray to empty
- With **pura3000** filtration
- Optional **puraguard** Antibacterial and antiviral protection

COLOUR OPTIONS



Brushed
Stainless Steel

COOLING OPTIONS



Refrigerated



Non-refrigerated

WATER OPTIONS



Chilled



Filtered



Ambient

INSTALLATION OPTIONS



Wall Mounted

DIMENSIONS

Height:	480mm
Width:	448mm
Depth:	473mm

The VersaFountain is ideal for busy venues, such as public buildings, gyms and sports complexes, hospitals, schools, and offices.

Puraguard is a ground-breaking protective antimicrobial coating that can be applied to your dispensers taps on request, providing 24hr protection against the growth of microbes (bacteria, moulds, fungi and viruses).

INSTALLATION

All dimensions are in inches. Dimensions in brackets [] are in millimetres.

NOTES:

1. TRAP, STOP VALVE AND ELECTRICAL OUTLET NOT FURNISHED.
2. ALLOW 4 INCHES [102 MM] MIN. PER SIDE FOR VENTILATION.
- *3. RECOMMENDED ADULT BARRIER FREE HEIGHT INSTALLATION SHOWN. REDUCE HEIGHT BY 3 INCHES FOR INSTALLATIONS USED PRIMARILY BY CHILDREN AGES 12 AND YOUNGER. UNIT SHALL ALSO HAVE A MINIMUM CLEAR FLOOR SPACE 30[760] BY 48[1220]. ADJUST VERTICAL DIMENSIONS AS REQ'D TO COMPLY WITH FEDERAL, STATE, AND LOCAL CODES.

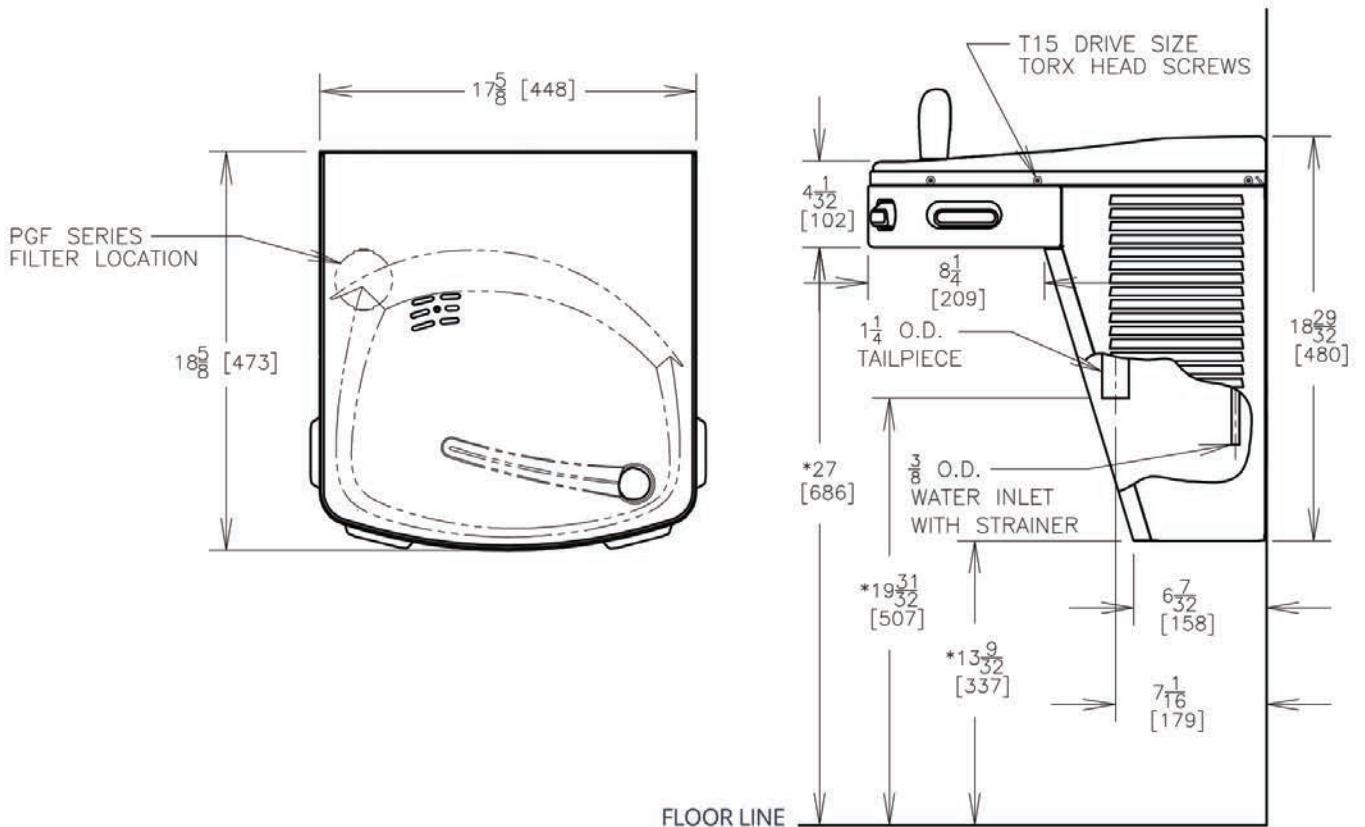

FULL SPECIFICATION VersaFountain surface-mounted cold water fountain.

Power consumption	220-240V, 50/60 Hz	
Cold tank capacity	Refrigerated 60 litres	
Dimensions	448mm (W) x 473mm (D) x 480mm (H)	
Weight	Refrigerated 27kg	Non-refrigerated 11kg

AVAILABLE ACCESSORIES



Paper Cups

- 7oz recyclable paper cups
- 7oz biodegradable and compostable paper cups
- 4oz biodegradable paper cones



Puraguard

- Antibacterial and Antiviral Protection Coating



Pura 500 Filtration

Our range of Pura filters have been developed to use our advanced filtration technology, retaining trace minerals in the water but removing harmful contaminants, sediment, and trace plastics down to 1 micron size